

Grand Renewable Energy 2018 International Conference

Efforts of Smart Community in Miyako Island



Naoto Higa

INTRODUCTION

There are 11 power grids in Okinawa. In 10 remote island power grids, excluding the main island, electricity is mainly supplied by diesel generators, and the generation cost is high. The annual load factor (= average/maximum) has been getting worse, which has led to further increase in the generation cost.

We would like to raise the self-sufficiency rate of energy within the Miyako Island from 3% to 20% or more by introducing renewable energy sources (RESs) and other distributed energy resources (DERs).

<Miyako Island>

Population : about 55,000

Electrical load : 25MW – 60MW

Annual load factor : less than 50%

The CO2 reduction target :

44% in 2030 , compared to 2003.

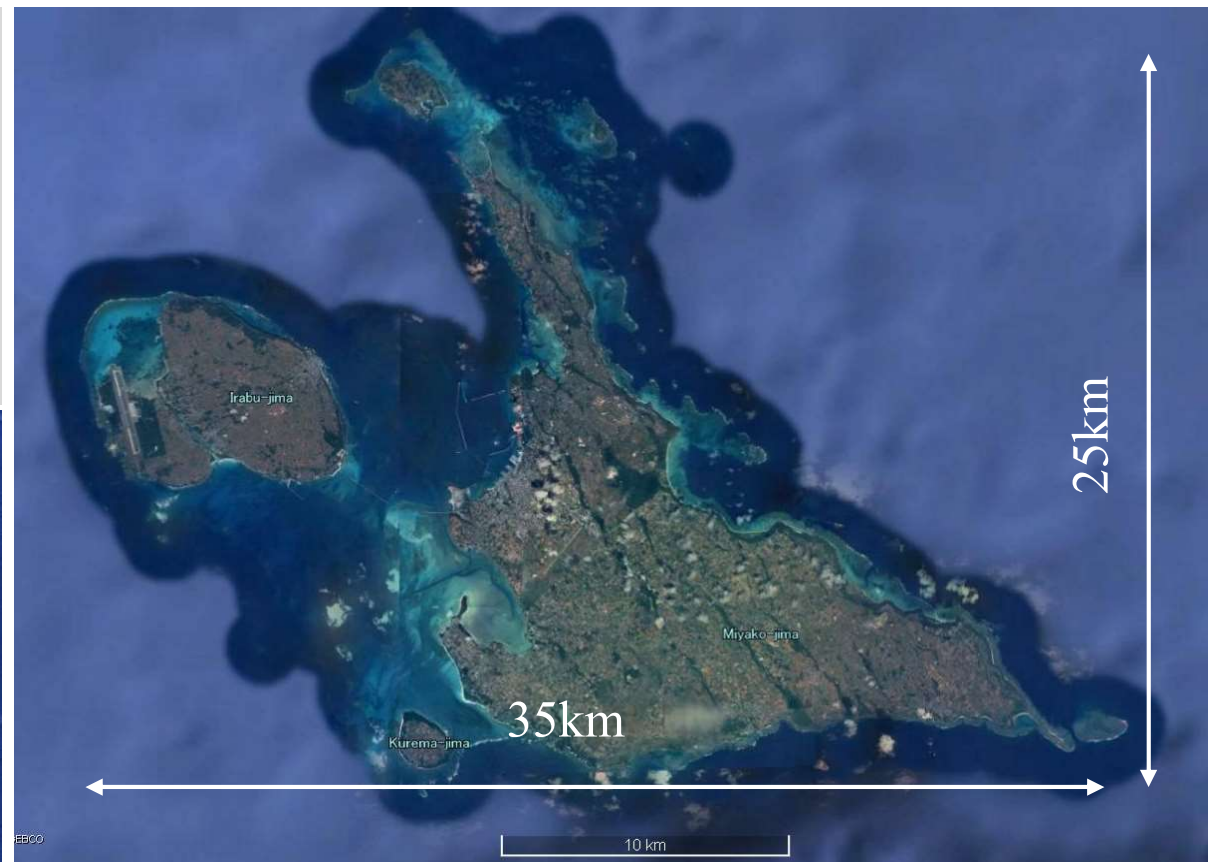

TECHNICAL RESEARCH

We have conducted technical researches to increase the load factor and for maximum use of RESs. We focused on home appliances to obtain sustainable and inexpensive technical methods to meet the demand of islands. Home appliances of which prices decline such as Photovoltaic systems (PV), Heat Pump Water Heaters (HPWH), Battery Energy Storage Systems (BESS), and EV Charging System (EVCS) are chosen to controlled devices. In addition, because they are home appliances, control methods consider multi-vendors, adopt standard protocols and cloud control systems as much as possible (Fig 1). We have studied deployment models of the DER management systems and propose control methods of DERs.

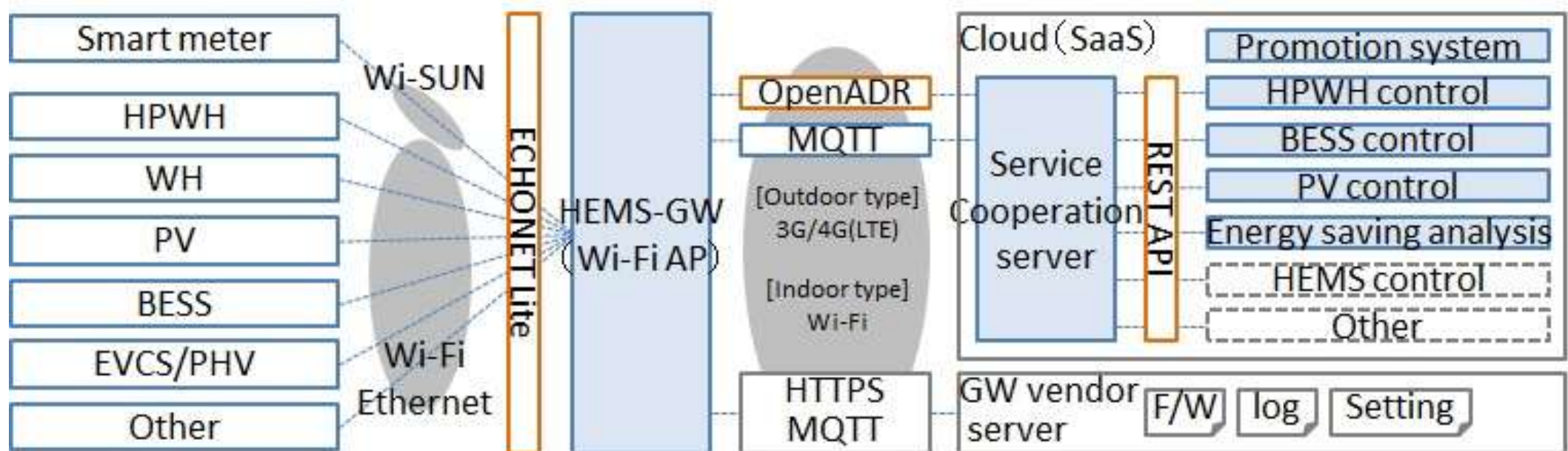

DEPLOYMENT MODEL

Deployment model of the controlled devices is a Third-Party-Ownership (TPO) combining a rooftop PV and a HPWH. For the Rooftop PV, we use a stand with a tilt angle of 5° , and an adhesive for bonding with the roof part. The HPWH is combined with the PV-PCS to be mounted on a self-supportive stand, considering that there is no burden on housing. The self-supportive stand has a structure to extend cables for BESS and EVCS (Fig 2). Initially TPO-IPP (Independent Power Producer) model intends to be sold PV power wholesale, and when the BESS is additionally installed, the deployment model will be switch to TPO-PPA (Power Purchase Agreement) model which retails power to housings. In addition, hot water from the HPWH is planning to be sold to hot water retailers in the housing. This deployment model is expected to reduce the average energy cost of conventional housing by about 20%.

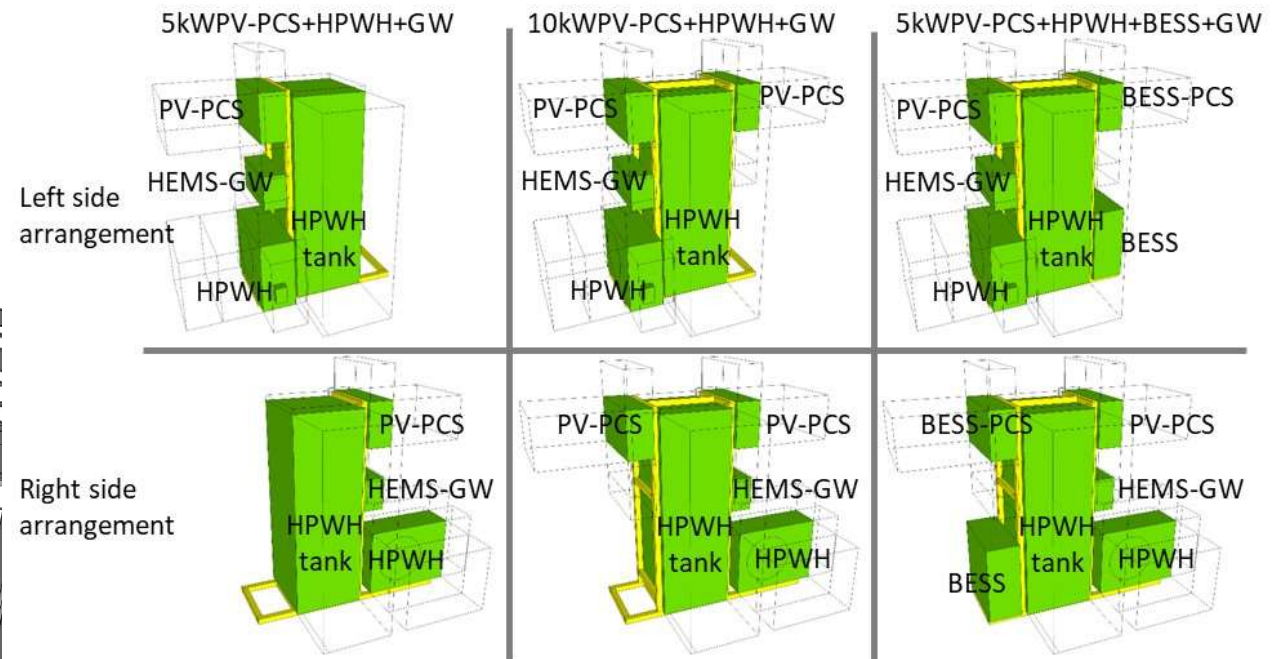
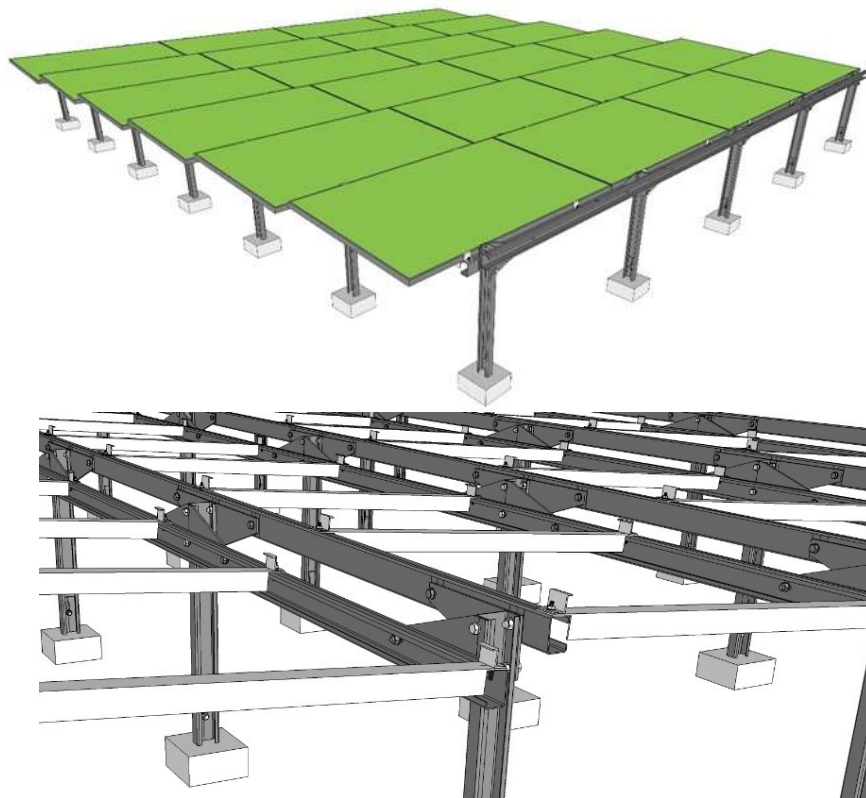

CONTROL METHOD

Control devices for PV always restrict maximum PV output to a certain level, unless PV-PCS capacity is much lower than PV panel capacity.

By this operation, we aim for stable power supply by enhancing predictability of PV output without large loss of PV generation. For example, even when we restrict the maximum output to 70% in summer and 40% in winter, annual power generation can be secured to 90%. (Fig 3).

The HPWHs and the BESS are both scheduled on the previous day and the operation time shift control is performed.

This demand response scheme is called Shift Demand Response (Shift-DR), in which DERs are controlled with local groups, and form the demand of the whole island power system of the next day. It is called “Area aggregation”. The purpose of Area aggregation is to improve the load factor of the whole power system and the maximum usage of renewables.

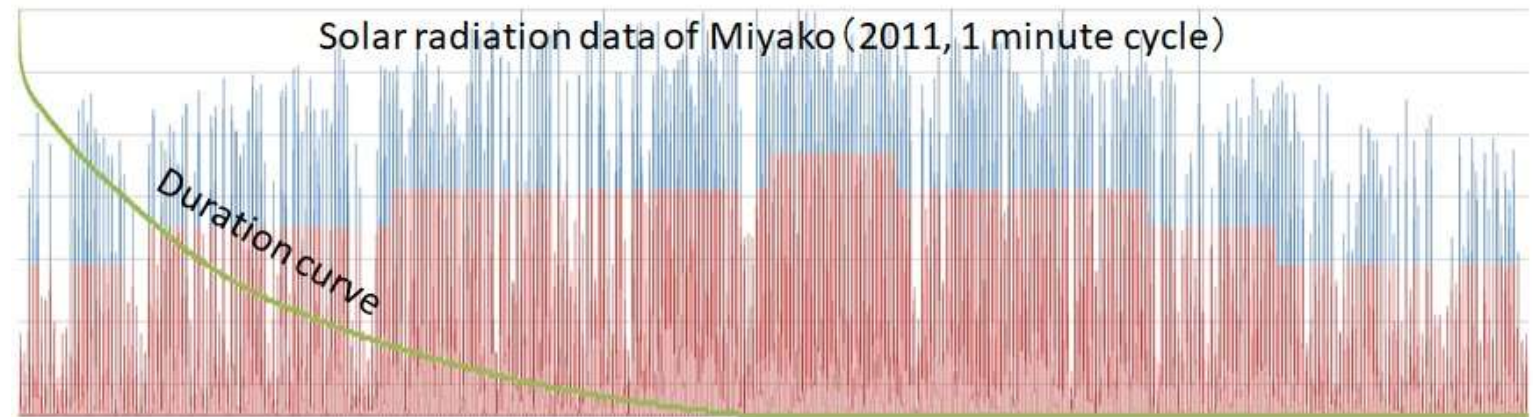

Output limit rate	PV Monthly power generation rate												
	Jan.	Feb.	Mar.	Apr.	May	Jun.	Jul.	Aug.	Sep.	Oct.	Nov.	Dec.	Total
100%	100.0%	100.0%	100.0%	100.0%	100.0%	100.0%	100.0%	100.0%	100.0%	100.0%	100.0%	100.0%	100.0%
90%	100.0%	100.0%	99.9%	99.8%	99.7%	99.8%	99.6%	99.8%	99.9%	100.0%	100.0%	100.0%	99.8%
80%	100.0%	99.9%	99.3%	98.7%	98.7%	98.3%	97.5%	98.4%	99.1%	99.9%	100.0%	100.0%	98.9%
70%	99.8%	98.9%	97.7%	95.6%	96.5%	95.2%	93.2%	95.0%	96.2%	99.2%	99.6%	99.9%	96.4%
60%	98.7%	95.8%	94.6%	90.4%	92.9%	90.2%	87.1%	89.9%	91.0%	96.2%	98.3%	99.4%	92.3%
50%	95.4%	90.2%	89.7%	83.1%	87.7%	83.0%	79.0%	83.1%	83.8%	90.9%	95.0%	97.1%	86.1%
40%	90.6%	82.3%	82.6%	73.7%	80.2%	73.4%	69.1%	74.2%	74.0%	83.1%	89.4%	92.7%	77.7%
30%	83.3%	71.3%	72.1%	61.6%	69.4%	60.9%	56.7%	62.8%	61.4%	71.9%	80.1%	85.3%	66.4%
20%	70.5%	55.3%	56.6%	45.9%	53.6%	45.1%	41.6%	47.3%	45.3%	55.5%	65.3%	72.2%	51.0%
10%	47.7%	32.8%	34.9%	25.9%	31.3%	25.0%	22.9%	26.7%	25.2%	32.4%	40.9%	47.1%	29.8%
0%	0%	0%	0%	0%	0%	0%	0%	0%	0%	0%	0%	0%	0%

NEGOTIATION WITH LPG SUPPLIERS

There are about 13 propane gas (LPG) suppliers in Miyako Island.

We negotiated with each suppliers about the deployment model of PV + HPWH. Although they understood the necessity of this model, most of them could not deny that it might cause their companies bankruptcy if this model spreads rapidly. Therefore, we are so far gradually planning to introduce the LPG equipment hybrid system. (Fig. 4)

HPWH supply 50°C hot water to the LPG water heater and restrict it to operate and reduce LPG consumption.

After years of confirming this operability, we are able to abolish the LPG water heater and replace them to LPG equipment hybrid system. We will promote the original deployment model, but gradually let the island's LPG operators to spread this management themselves, and aim to expand their business closely with the local sites.

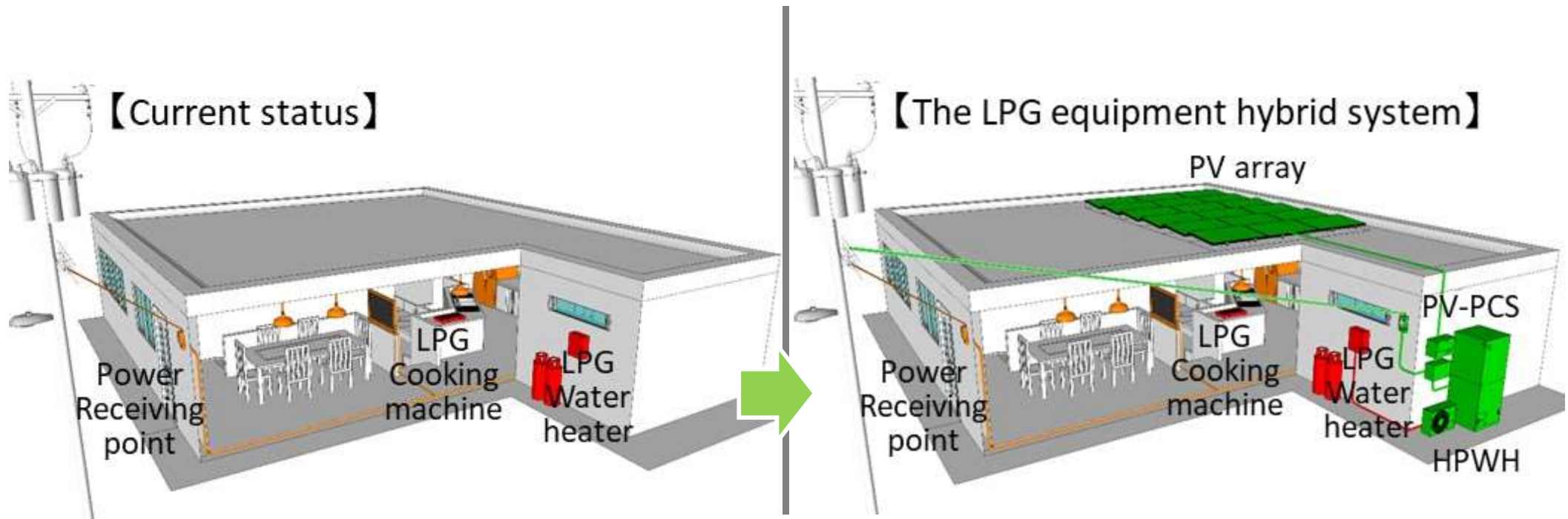

NEGOTIATION WITH POWER COMPANY

Although RES connection capacity has already been reached, in order to further expand RES, we have an understanding of improving predictability by the PV constant output limit and controlling Shift-DR value by DER control. On the other hand, if deployment models of PV + HPWH spread widely, and creating next day power demand by Area aggregation, we predict that electric power fluctuation will hardly occur, even in a small-scale electric power system of a remote island. However, the current situation like this transition period is severe. At present, the RES output variation and the load variation are rapidly changing within several minutes.

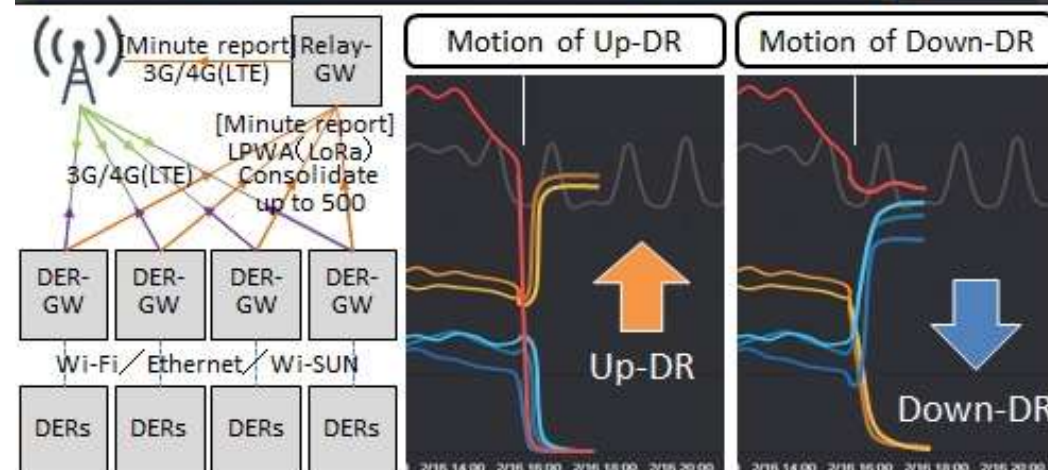
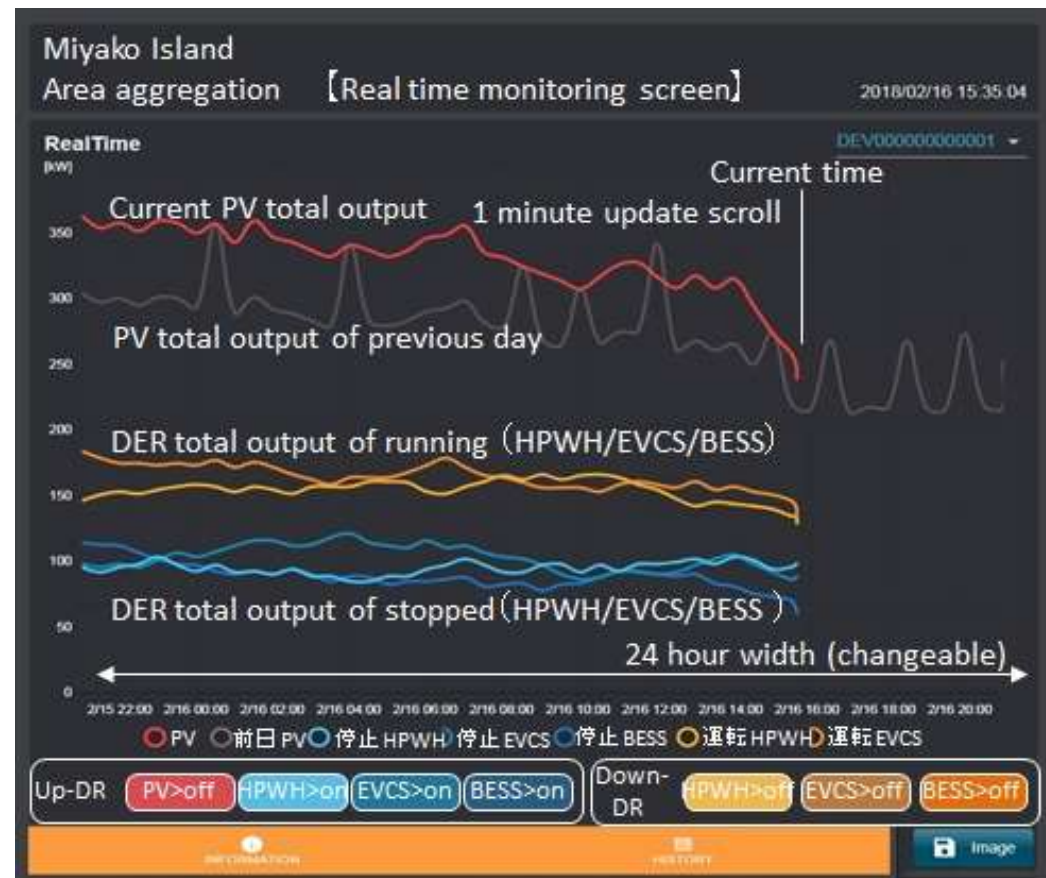

NEGOTIATION WITH POWER COMPANY

In this project, we have planned to only employ the gentle control of the Shift-DR, but it is necessary for us to find out the Fast-DR by minutes. Therefore, we divided the communication into UPLINK and DOWNLINK, and decided to use LoRa communication which is a type of LPWA (Low Power Wide Area) for UPLINK. By application of this system, the diesel power station would be possible to carry out real-time monitoring and it is useful for PV output monitoring at regular times. In addition, and in times of emergency such as insufficient lifting capacity or the lack of remaining capacity of the diesel generator, control command such as PV stop and HPWH operation / stop will be transmitted by LTE communication.

By choosing such a method, we believe that even if monitoring and controlling DER in real time, operational costs can be realized at low cost. (Fig. 5)

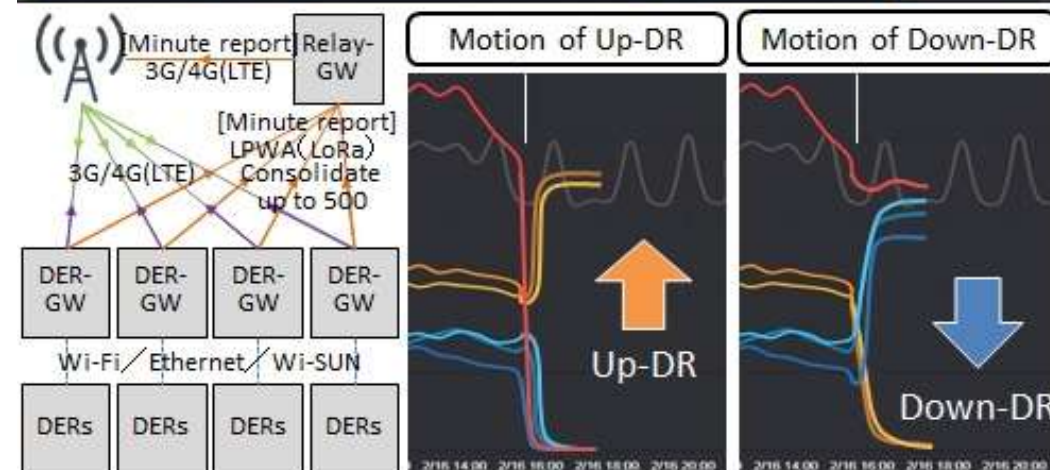
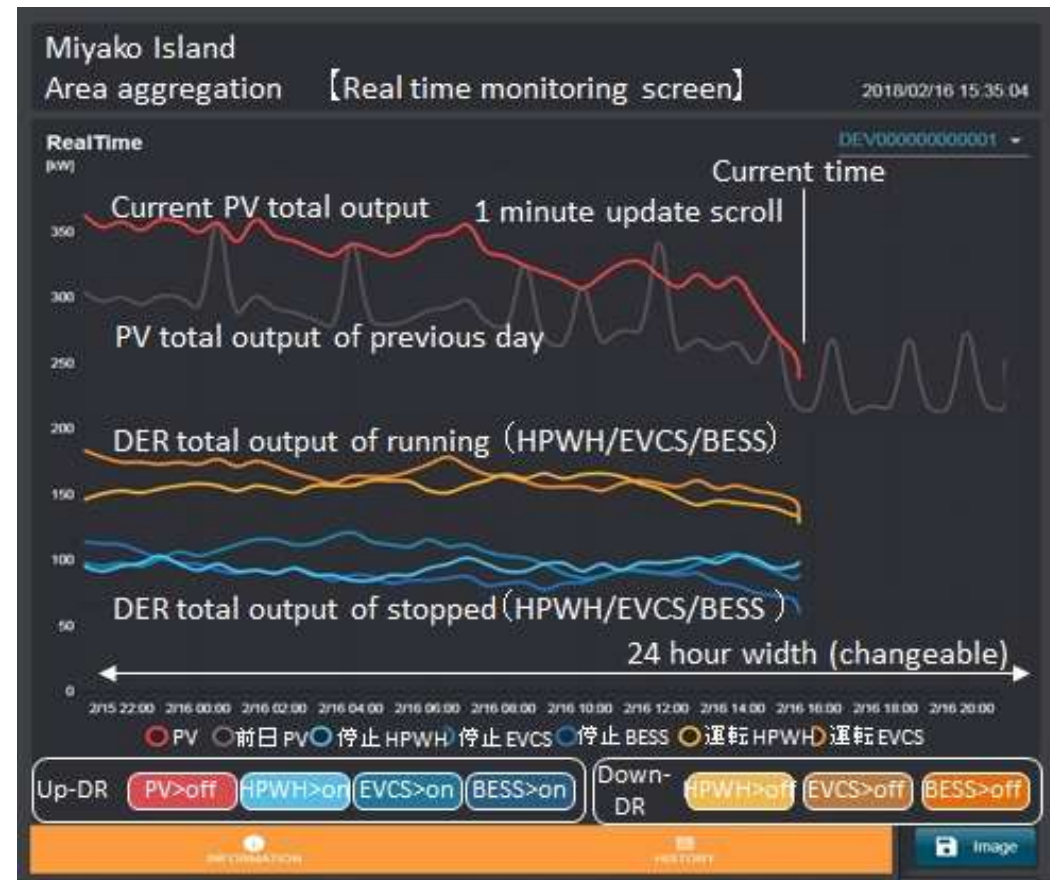

FUTURE ASSUMPTIONS

The price drop of PV panels and PV-PCS is also progressing rapidly. We are making future assumptions for stable power supply (Fig 4).

First of all, we will deploy PV+HPWH to low-voltage lines using the TPO-IPP model. Using the controlled devices, the Master aggregator cooperates with Area aggregators and the servers create island's total demand for the next day.

Next, in case of kWh value falls and the kW value rises. We assume that BESS for peak-cut will become popular in high-voltage lines. In addition, the deployment of EVs is also accelerated, and the number of EV charging stations will increase rapidly.

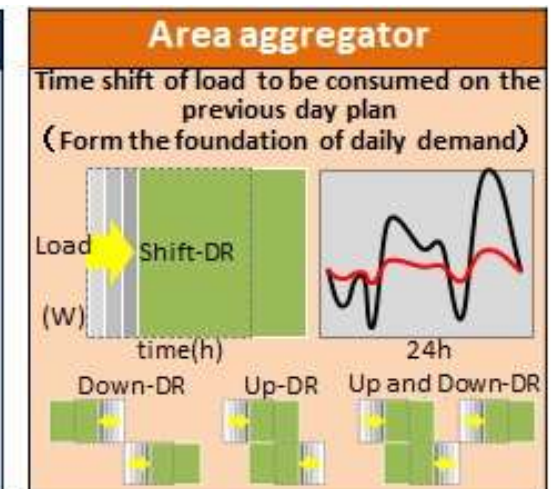
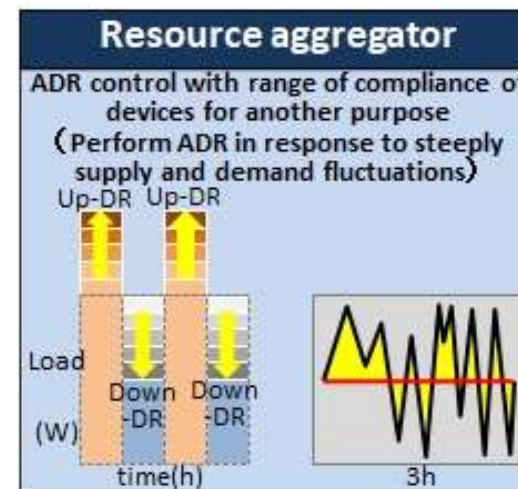
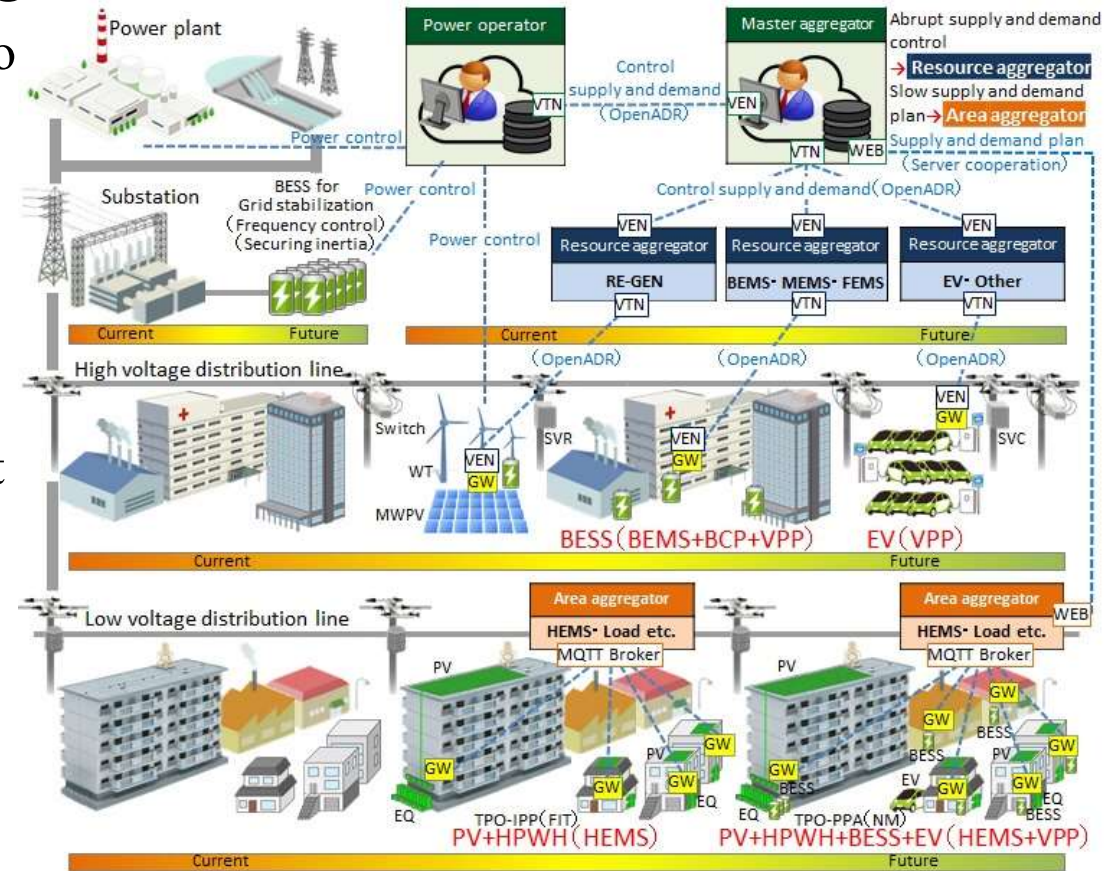

RECENT PLANS

At Miyako Island, there are plans to verify the effectiveness of Area aggregation by deploying up to 5000 units of set of DERs in the TPO-IPP model over the next 3 years. By this project, we are planning to double the PV of about 24 MW currently being introduced to about 50 MW to Miyako Island, whose current load is 25 MW - 60 MW.

Therefore, we will establish the control value of DER which is the control target equipment, and establish a hot water selling method, equipment procurement method and system connection method.

By combining these, we would like to realize Area aggregation, and make PV a main power source, while improving the self-sufficiency energy rate within the island from 3% to 20%, and produce a power system with low power generation cost.

